

Case Study in Exterior Storm Windows

Lyman House Weatherization Project: Exterior Storm Windows

A Component of Energy Retrofit project supported by Massachusetts Department of Energy Resources

Work completed August 2011-December 2011

Pre-Work

Statement of Condition

Exterior storm windows were extant on the west wing of the mansion house. The date of installation of these storm windows is unknown. The existing aluminum storm windows were white ðtriple track storm windows in varying degrees of functionality. In some cases, the screen and / or glass panels were missing. In other cases, the panels were no longer movable. Where screen and glass panels existed and were functional, there was no seasonal plan to appropriately set the panels.



Example of existing exterior storm window prior to 2011 work

Treatment Plan (scope of work)

The DOER funded retrofit project provided for the installation of new exterior storm windows as one component to air sealing. As the project was geared towards identifying and measuring sensitive alterations to the building, it was decided to install two types of exterior storm windows ó aluminum and wooden.

Philosophical Approach

As storm windows were extant, it was in keeping with Historic New England's philosophy to replace the existing exterior storm windows with new exterior storm windows. Technically, the new windows were not replacing in kind as there was the opportunity to upgrade the quality and functionality as well as the aesthetic component.

Property Care White Papers

Weatherization Case Study Exterior Storm Windows

Work

Work Performed

It was recommended and approved by Historic New England's interpretive that those windows on the front of the house and the loading dock area were to be treated with wooden storm windows while those windows the rear of the house were to be treated with aluminum storm windows.



Exterior Wooden Storm Window Treatment

South elevation, 2nd floor office windows



West elevation, 2nd floor office windows and 1st floor kitchen

Note that the three windows not highlighted did not have exterior storm windows and thus were treated with

Property Care White Papers Weatherization Case Study Exterior Storm Windows

The wooden storm windows were custom made by Architectural Detail in Wood, based in Shirley, MA. After templating each opening for precise fit of the storm window, the windows were crafted from Honduran Mahogany using traditional pegged mortise and tenon joinery with a middle rail that aligns with the meeting rail of the double hung sash. Modern float glass of 1/8" thickness was used.

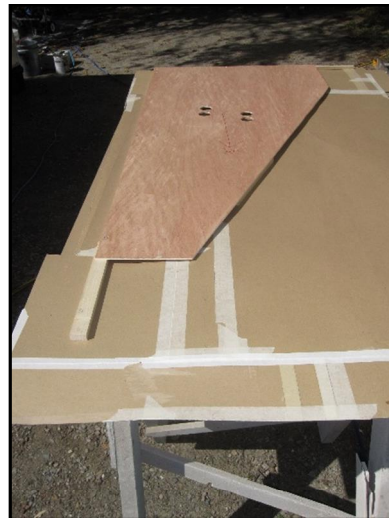
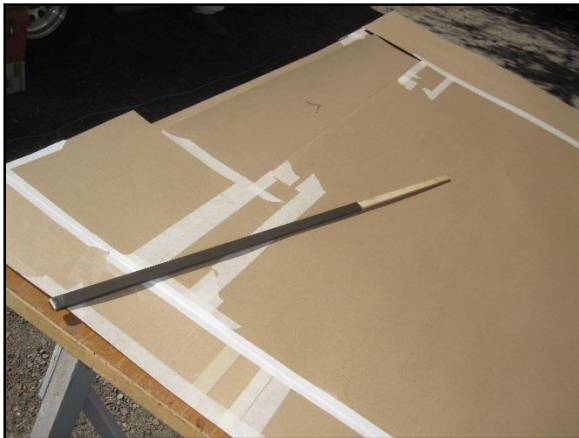

Template development for each opening

Property Care White Papers Weatherization Case Study Exterior Storm Windows

The upper light is fixed and reverse glazed meaning a beveled profile similar to that provided by standard glazing putty is milled into the exterior face of the storm window. The light is secured from the inside with silicone and held in place with a wooden stop. This results in the appearance of a traditionally glazed window without the need to periodically re-glaze the unit. The window was weather stripped with a silicone bulb at the sill. The lower light is an aluminum framed glass panel that is held in place with two brass clips. This light can be replaced seasonally with an aluminum framed screen.



Storm window frames ready for dry fit to each opening

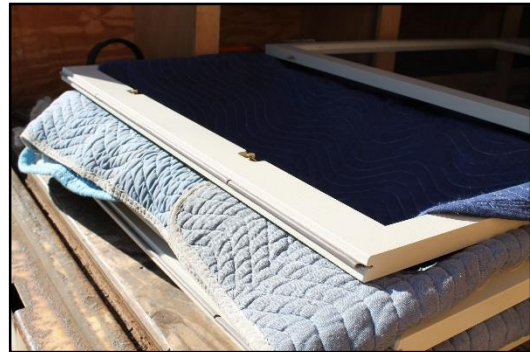

Silicone weather stripping



Brass hardware for securing lower light removable panel



Brass pins to set in head casing

This wooden storm window fits flush in the window opening, seated against the blind stop. Two brass pins poke into the head casing and the window is held tightly to the blind stops with brass hardware installed from the inside. This installation differs from a more traditional wooden storm window installation where the window hangs over the face of the window opening. As there was no photographic evidence of such an exterior storm window for the Lyman House, there was no intent to install that type. As such these storm windows present a minimal visual impact when viewed from the outside.

**Property Care White Papers
Weatherization Case Study Exterior Storm Windows**



Installation



Completed installation



Hardware

Property Care White Papers Weatherization Case Study Exterior Storm Windows



Exterior Aluminum Storm Window Treatment

*North elevation, 2nd floor office windows
and 1st floor kitchen and service wing*



Historic New England's experience with exterior storm windows has been limited over the years, although many properties have some form of exterior storm window. Where installed, most appear to be a common, mass-marketed "triple track" storm window of a stock color. These "triple track" storm windows have two glass panels and one screen panel, with each panel sliding independently in its own track to allow varying options for sealing. Some properties have single "dead light" storm panels installed as a seasonal maintenance task; in some cases, only the frames remain as the lights have been damaged or otherwise lost to time. Effectiveness of blocking air infiltration has never been measured and documented.

During the review of interior storm window options, one player was also seen as a quality exterior product providing a low profile option that would minimally impact the visual aesthetic of the property. Allied Window's Historic One Lite with removable bottom pane was selected for the rear facing windows.

The top is fixed and the bottom panel is removable to the interior. An interchangeable screen for this bottom panel was included in the purchase. The horizontal divider for the master frame of the (HOL) is aligned with the meeting rail on the existing window.

Property Care White Papers Weatherization Case Study Exterior Storm Windows

Drawing details of Allied HOL exterior storm window

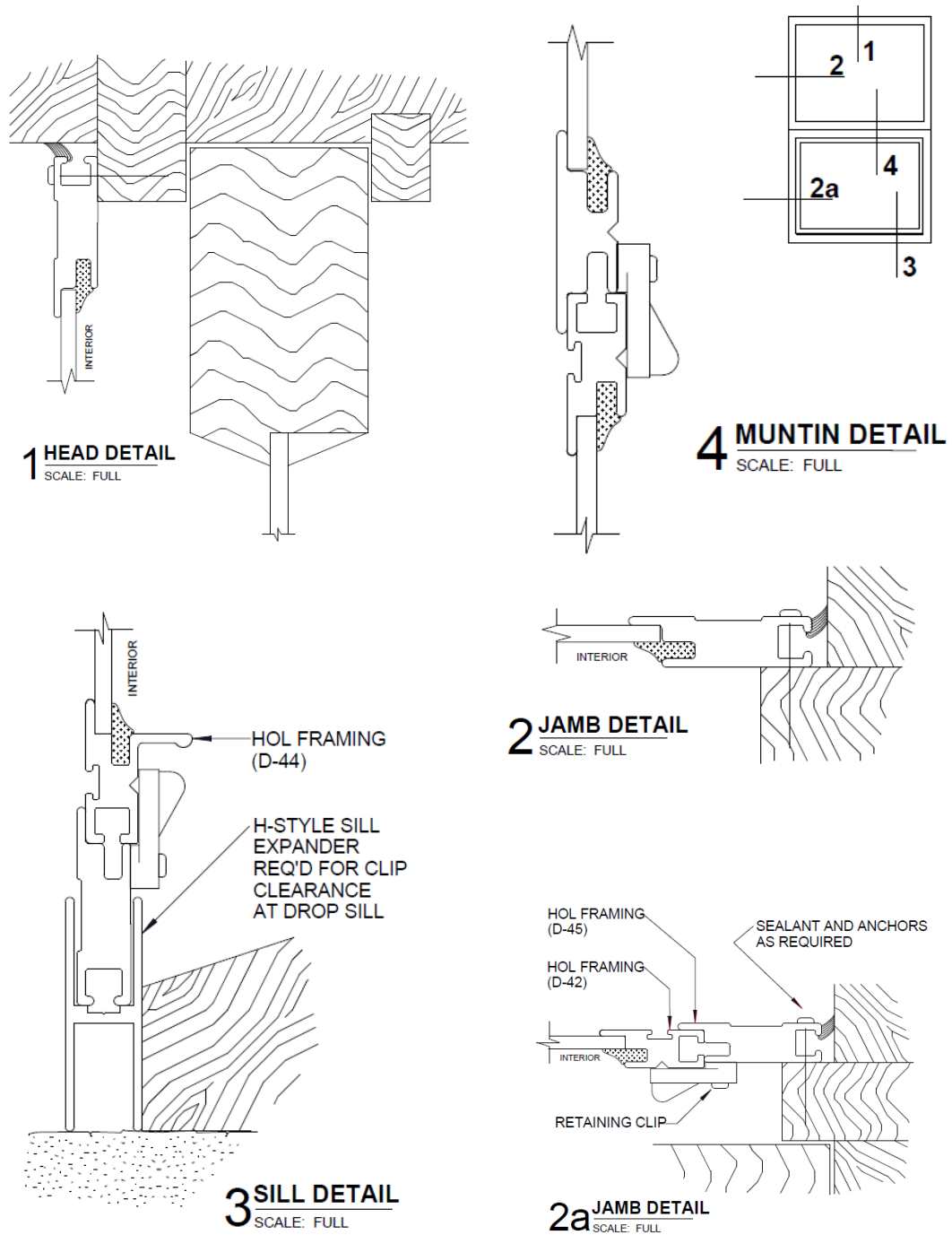

The Allied storm windows were installed by Heritage Restoration of Providence, RI.

Property Care White Papers Weatherization Case Study Exterior Storm Windows



*L-bracket secured to window's blind stop
at both sides and top*



*Storm window is slipped into bottom
expander*

L-bracket is caulked

*Storm window is seated into bracket and
screwed to L-bracket*

Bottom expander is adjusted for fit against



Property Care White Papers Weatherization Case Study Exterior Storm Windows

Energy Efficiency Metrics

After installation of the exterior storm windows, various blower door tests were performed on rooms with these storm windows. These rooms are three offices on the second floor of the west wing. Infiltration measurements found that there was an overall decrease in infiltration by 20% in each room tested. With the storm windows uninstalled, approximately 10% of the reduction could be attributed to the sash conservation and weatherization efforts. The interior storm windows performed about 10% better with respect to stopping air infiltration. However, there was no performance difference between the wooden and aluminum storm windows.

Maintenance Requirements

Both types of exterior storm windows have been designed and installed such that their removal should be a rare event, done only in conjunction with painting maintenance. Removal of the wooden storm windows requires someone on the inside to release the hardware and someone on the outside to catch the window upon its release. Removal of the aluminum storm windows requires unscrewing the window unit from the L-bracket frame.

Both types have been built to allow for the seasonal removal of the lower glass panel and the use of a screen panel. The unused panels are stored on the 3rd floor of the house and are numbered to correspond with the window schedule numbering.

For the venting of food preparation smells, three of the four windows in the kitchen area will likely always have the screen panel installed.

The wooden storm windows will require paint maintenance at the same time as schedule exterior paint maintenance. The aluminum storm windows should require no maintenance although it is important that the weep holes at the bottom are never painted or caulked shut.

Cost

Work Performed	Company	Amount
Exterior Aluminum Storm Windows (quantity 14)	Heritage Restoration	\$ 10,777.82
Exterior Wooden Storm Windows (quantity 12)	Architectural Detail in Wood	\$ 9,673.00
Total Exterior Storm Windows		\$20,450.82